

LEGENDA / LEGEND

Bloccare con frenafiletto: L= Leggera - M= Media - S= Forte
 Lock with the threadlocker: L= Light - M= Medium - S= Strong

OEM Parte della dotazione originale
 Original equipment manufacturer's part

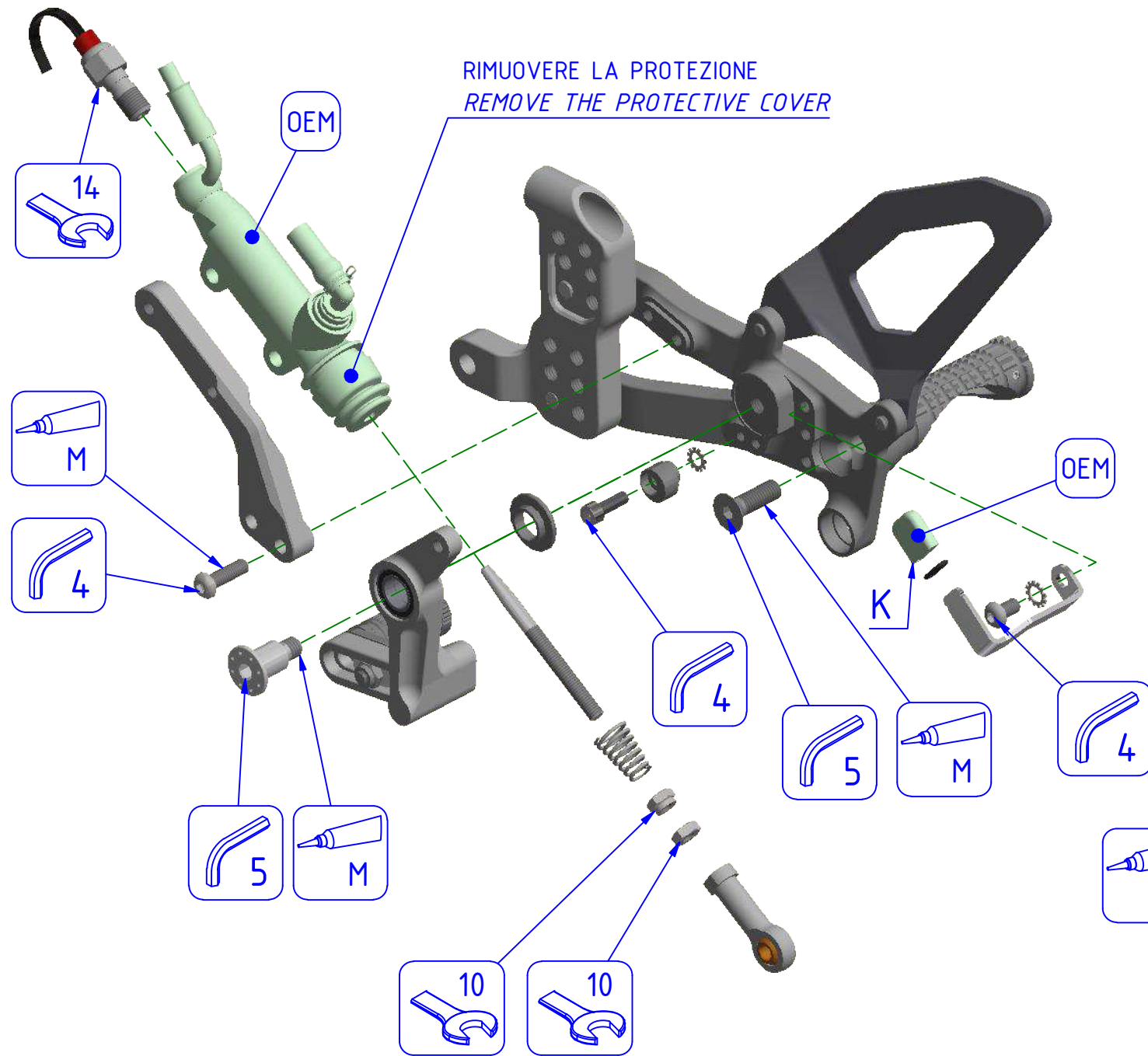

ATTENZIONE: Il montaggio del prodotto deve essere eseguito da personale specializzato.
 WARNING: The mounting of the product it must be realized from staff specialist

LATO FRENO
 BRAKE SIDE

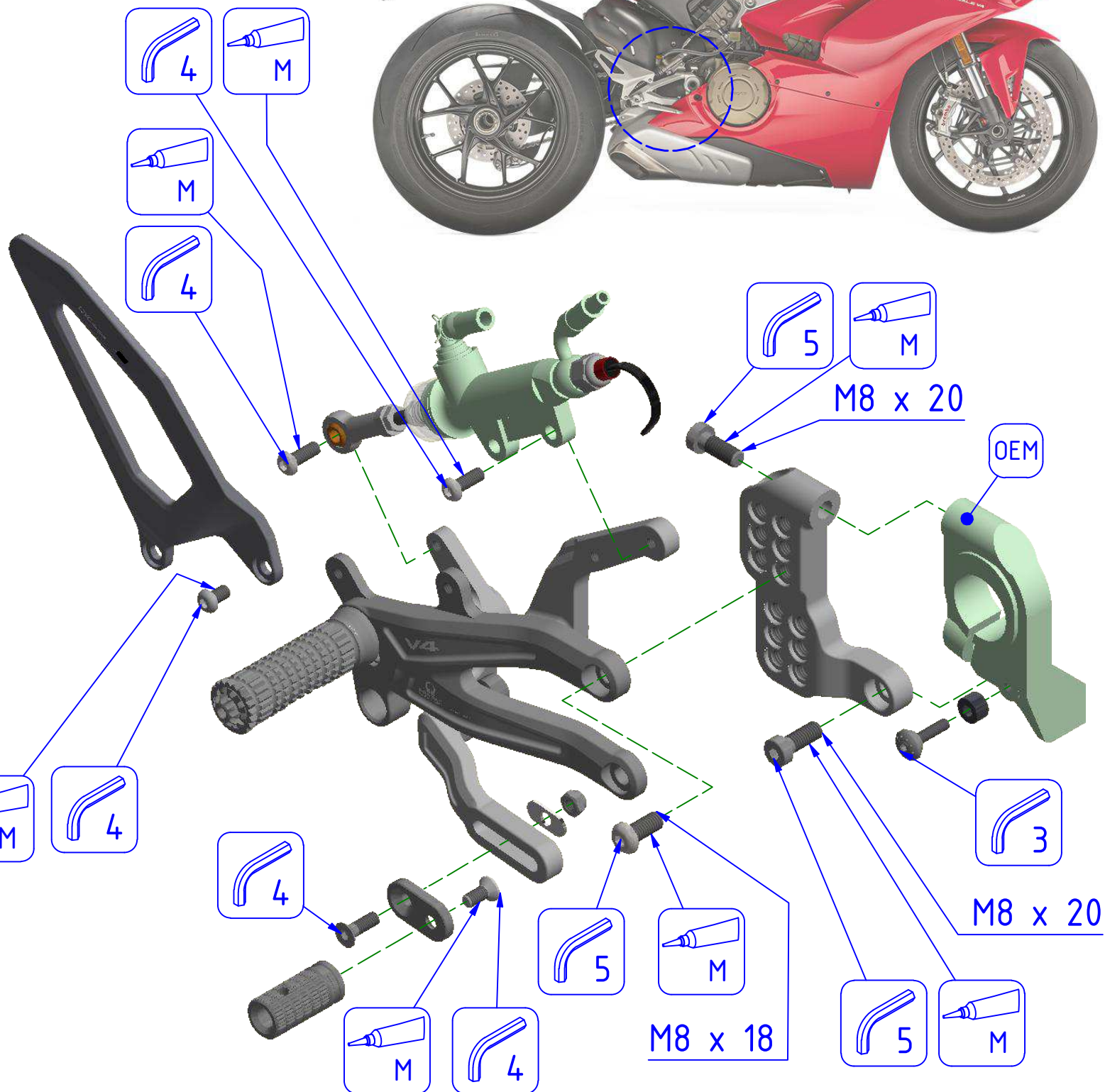

NOTA/NOTE:
 - K: In alternativa al particolare (Pos. 30) si può utilizzare il particolare OEM
 - K: In alternative to the particular (Pos. 30) the particular OEM can be used

ATTENZIONE: Questo prodotto potrebbe non essere conforme al codice stradale o alle leggi vigenti in alcuni paesi e quindi utilizzabili solo in aree private e/o chiuse al traffico.
 WARNING: This product may not comply with local road rules and regulations and can be used only in private areas and/or areas closed to traffic.

	ART:	ISTRUZIONI / INSTRUCTIONS
	PE407	PEDANE REGOLABILI RPS "EASY" ADJUSTABLE REAR SETS RPS "EASY"

LEGENDA / LEGEND

 Bloccare con frenafilletti: L= Leggera - M= Media - S= Forte
Lock with the threadlocker: L= Light - M= Medium - S= Strong

 Parte della dotazione originale
Original equipment manufacturer's part

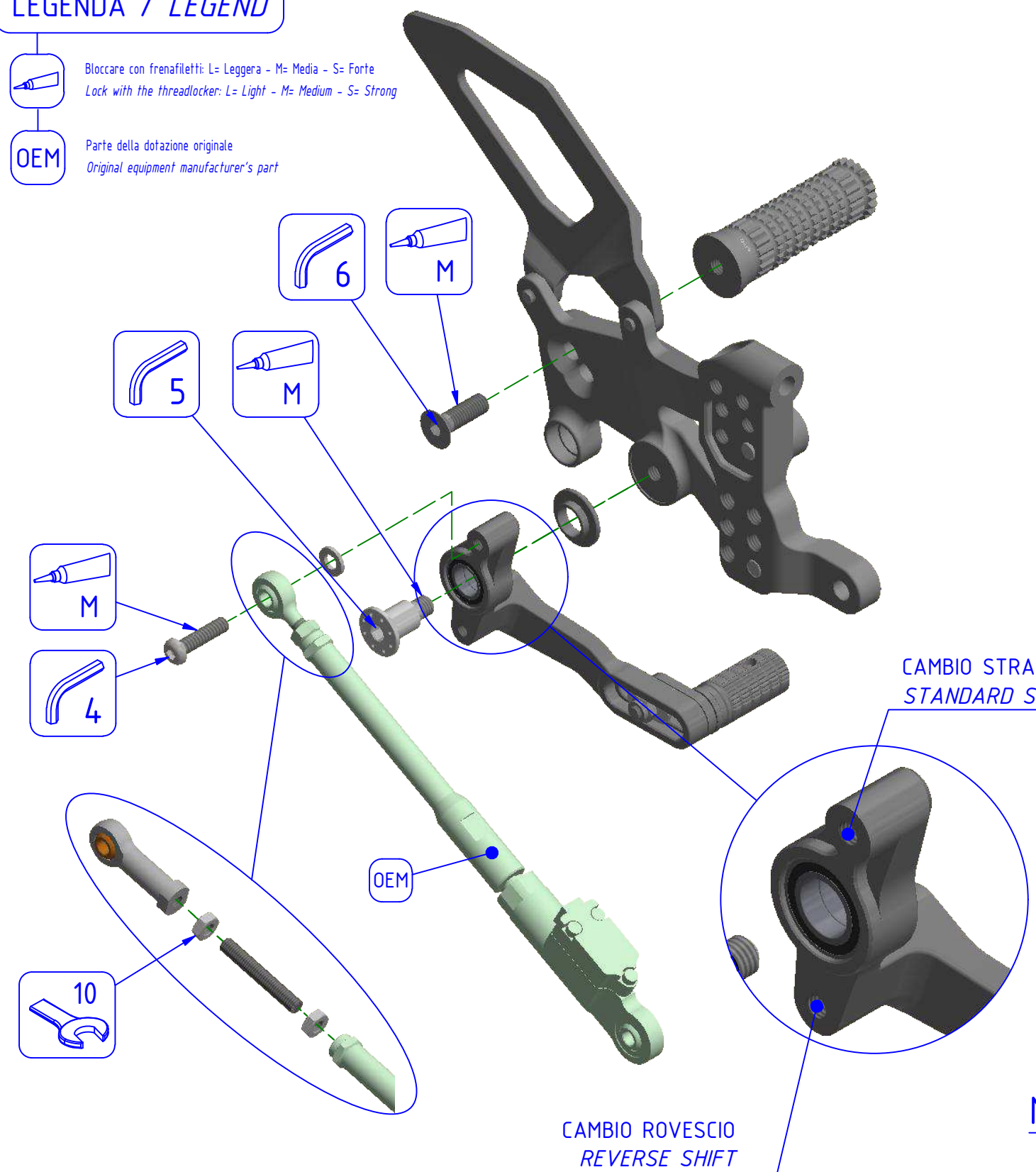

Per alcune configurazioni sostituire uniball OEM secondo lo schema indicato
For some configurations replace the OEM uniball according to the stated scheme

* PER IL SERRAGGIO DELLE VITI RIFARSI AL MANUALE DEL COSTRUTTORE
* FOR THE TIGHTENING OF THE SCREWS REFER TO THE MANUFACTURER'S MANUAL



ATTENZIONE: Il montaggio del prodotto deve essere eseguito da personale specializzato.
WARNING: The mounting of the product it must be realized from staff specialist

**LATO CAMBIO
SHIFT SIDE**



Immagine usata a fini esclusivamente illustrativi
Image used for illustrative purposes only

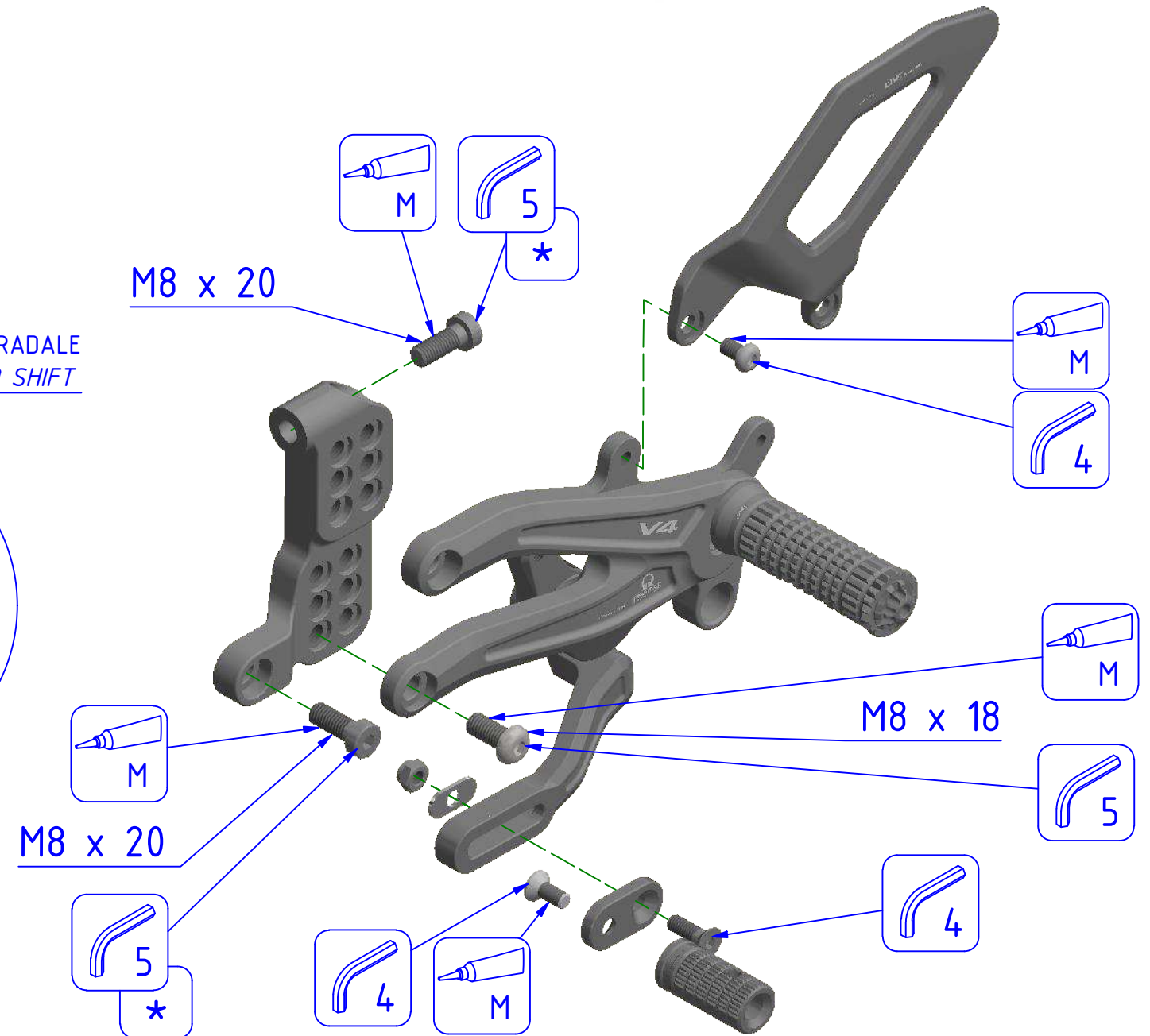

ATTENZIONE: Questo prodotto potrebbe non essere conforme al codice stradale o alle leggi vigenti in alcuni paesi e quindi utilizzabili solo in aree private e/o chiuse al traffico.
WARNING: This product may not comply with local road rules and regulations and can be used only in private areas and/or areas closed to traffic.

	ART:	ISTRUZIONI / INSTRUCTIONS PEDANE REGOLABILI RPS "EASY" ADJUSTABLE REAR SETS RPS "EASY"
	PE407	

A termini di legge ci riserviamo la proprietà di questo disegno con diritto di riproduzione o di rendere noto a terzi senza nostra autorizzazione. / Pursuant to law, we reserve the ownership of this drawing with prohibition to copy or disclosed to third parties without our authorization.

CNC RACING si riserva il diritto, a sua esclusiva discrezione, di apportare modifiche al prodotto e a queste informazioni in qualsiasi momento e senza preavviso. / CNC RACING reserves the right, in its sole discretion, to modify the product and this information at any time without prior notice.

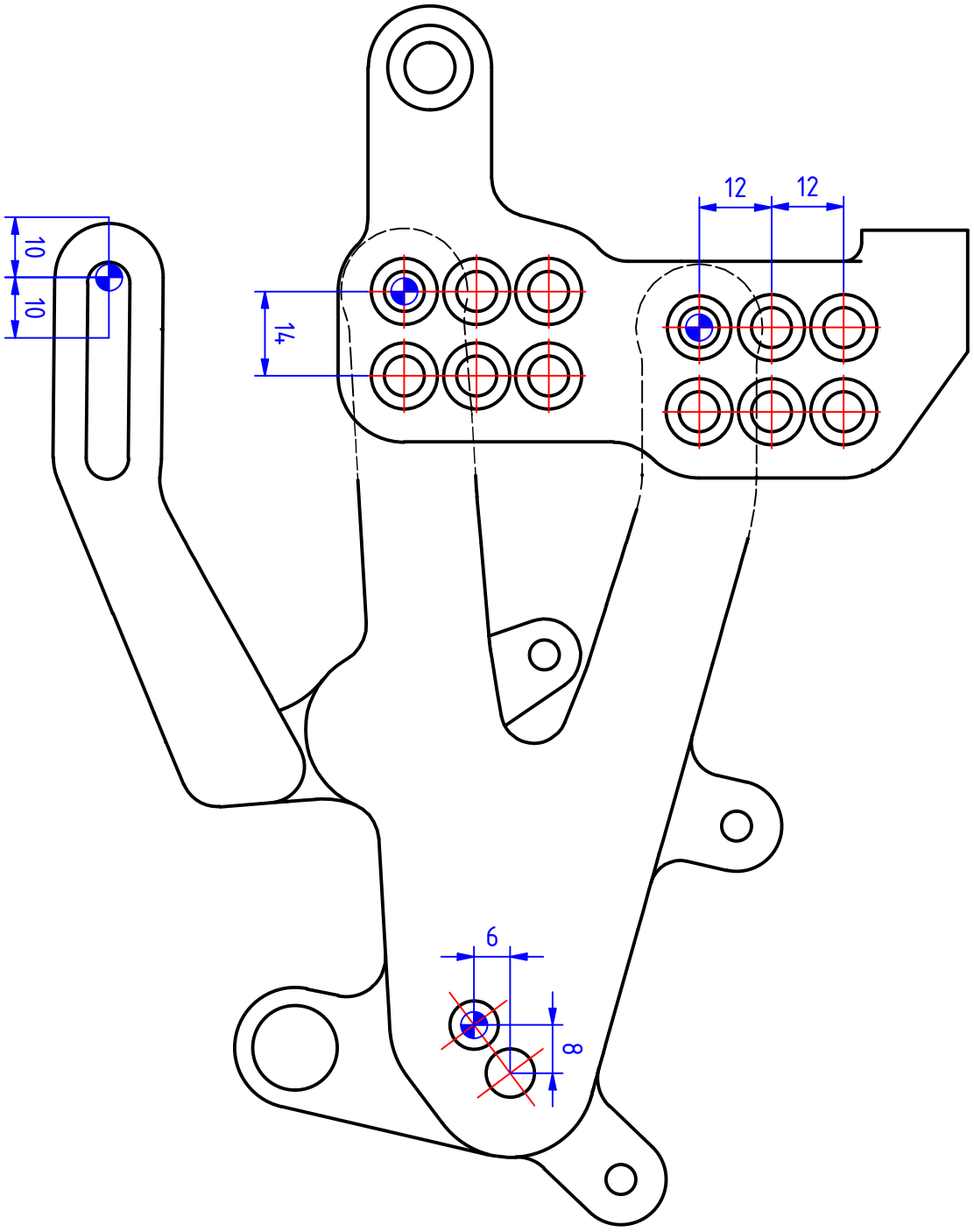

➔ POSIZIONE OEM / OEM POSITION



ATTENZIONE: Questo prodotto potrebbe non essere conforme al codice stradale o alle leggi vigenti in alcuni paesi e quindi utilizzabili solo in aree private e/o chiuse al traffico
 WARNING: This product may not comply with local road rules and regulations and can be used only in private areas and/or areas closed to traffic.



ART:

PE407

POSIZIONI POGGIPIEDE / FOOTPEGS POSITION

PEDANE REGOLABILI RPS "EASY"
 ADJUSTABLE REAR SETS RPS "EASY"