



**ATTENZIONE:** Il montaggio del prodotto deve essere eseguito da personale specializzato  
**WARNING:** The mounting of the product it must be realized from staff specialist

## LEGENDA / LEGEND



Bloccare con frenafilletti: L= Leggera - M= Media - S= Forte  
 Lock with the threadlocker: L= Light - M= Medium - S= Strong



Lubrificare ✓ / Non lubrificare ✗  
 Lubricate ✓ / Do not lubricate ✗

\*OEM = ORIGINAL EQUIPMENT MANUFACTURER



Immagine usata a fini esclusivamente illustrativi  
 Image used for illustrative purposes only



**ATTENZIONE:** Questo prodotto potrebbe non essere conforme al codice stradale o alle leggi vigenti in alcuni paesi e quindi utilizzabili solo in aree private e/o chiuse al traffico  
**WARNING:** This product may not comply with local road rules and regulations and can be used only in private areas and/or areas closed to traffic.

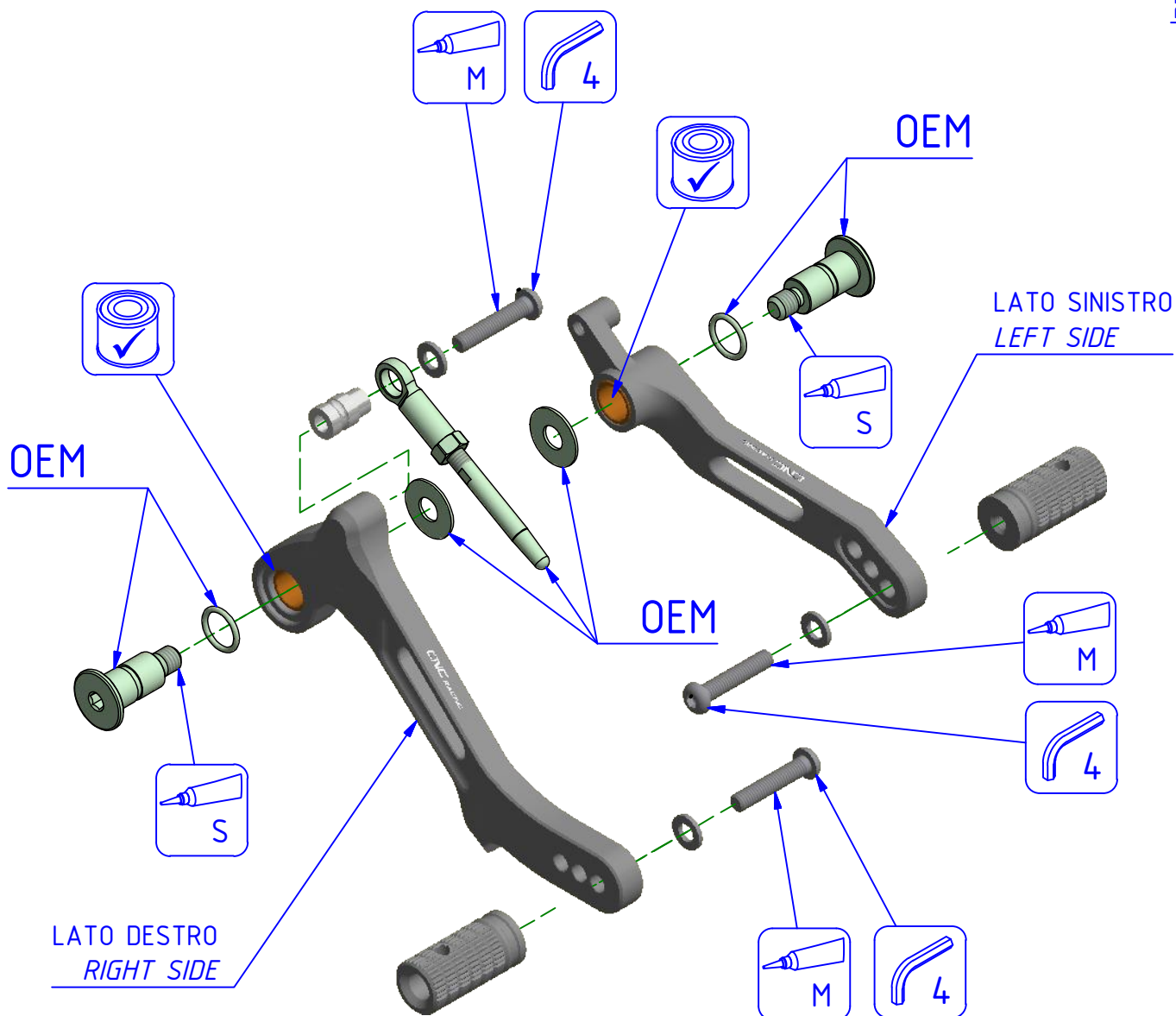
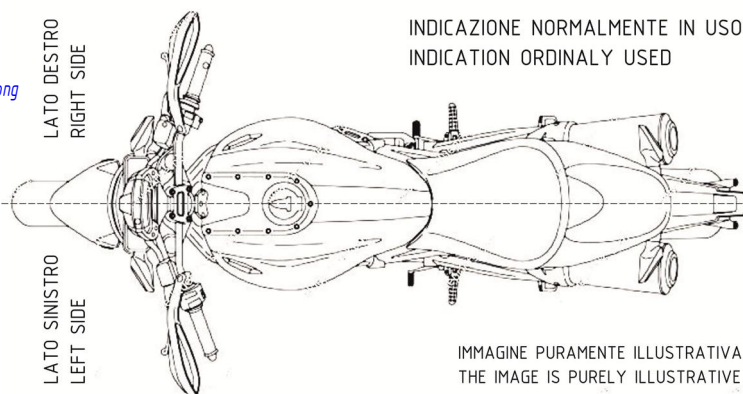

ART:  
 PE245

ISTRUZIONI / INSTRUCTIONS  
 KIT COMANDI PILOTA "EASY"  
 ADJUSTABLE LEVERS "EASY"

A termini di legge ci riserviamo la proprietà di questo disegno con divieto di riproduzione o di renderlo noto a terzi senza nostra autorizzazione. / Pursuant to law, we reserve the ownership of this drawing with prohibition to copy or disclosed to third parties without our authorization.  
 CNC RACING si riserva il diritto, a sua esclusiva discrezione, di apportare modifiche al prodotto e a queste informazioni in qualsiasi momento e senza preavviso. / CNC RACING reserves the right, in its sole discretion, to modify the product and this information at any time without prior notice.